

Technical data

	operation when connected accumulation mass		
	Certified values	Operating values	
	cupola	side output / cupola	
Energy label		----	
Operating data			
Nominal heat power	12 kW	----	
Efficiency	>85 %	----	
Consumption of wood	2,9 kg/h	12 kg	16 kg
Total heat output of the burning chamber ⁶	----	48 kW	64 kW
Average heat output / heat accumulation time ⁵	----	3,2 kW / 12 h	4,3 kW / 12 h
Mass flow of flue gas	11 g/s	30 g/s	45 g/s
Required chimney pressure	12 Pa	15 Pa	15 Pa
Required amount of combustion air	25 m ³ /h	105 m ³ /h	135 m ³ /h
Average flue gas temperature			
on the output (in front of accumulation mass)	362 °C	627 °C / 553 °C	721 °C / 635 °C
behind 2,1 m of ceramic accumulation set KMS 300	206 °C	----	----
behind 5,1 m of ceramic accumulation set KMS 300 ¹	----	181 °C / –	
behind 6,3 m of ceramic accumulation set KMS 300 ¹	----	----	185 °C / –
Heat distribution			
heating insert	30-40 %		
door glass (single / double)	15 %		
additional accumulation mass	45-55 %		
Information for ventilated builds			
Minimal grill area supply / outgoing	900 / 1050 cm ²		
Minimum distance from insulated areas / floor	80 / 0 mm		
Reference insulation ² ceiling / back wall / side wall / floor	140 / 100 / 100 / 0 mm		
Calciumsilicate insulation ³ ceiling / back wall / side wall / floor	110 / 80 / 80 / 0 mm		
Information for non-ventilated builds (closed grills)			
Minimum radiant area ⁴	suitable	8,5 m ²	
Minimum distance from insulated areas / floor	80 / 20 mm		
Reference insulation ² ceiling / back wall / side wall / floor	190 / 140 / 140 / 40 mm		
Calciumsilicate insulation ³ ceiling / back wall / side wall / floor	140 / 110 / 110 / 25 mm		
General technical information			
Total weight / lining weight	circa 270 / 120 kg		
Burning chamber dimensions (width x depth)	305 x 525 mm		
Combustion air connection	Ø 150 mm		
Use in non-ventilated accumulation builds according to craft rules	suitable ⁴	----	
Tested according to	EN 13229	----	
Meets values	1. BImSchV (Stufe2), 15a BVG	----	

1 Listed value from testing. For accurate results is evaluation of each system in the Ortner / KOV program necessary

2 Mineral wool according to AGI-Q 132

3 Example SkamoEnclosure Board 225 kg/m³

4 Depends on accumulation period and material characteristics. Listed values calculated with average specific heat output = approx. 500 W/m²

5 Storage operation, one wood charge for storage duration, with closed construction and efficiency > 80%

6 With maximum possible fuel quantity wood 4 kWh/kg, without consideration of efficiency losses

HE 37/50G

Technical data
Version 09/2023

HE 37/50G additional smoke outlet Ø180

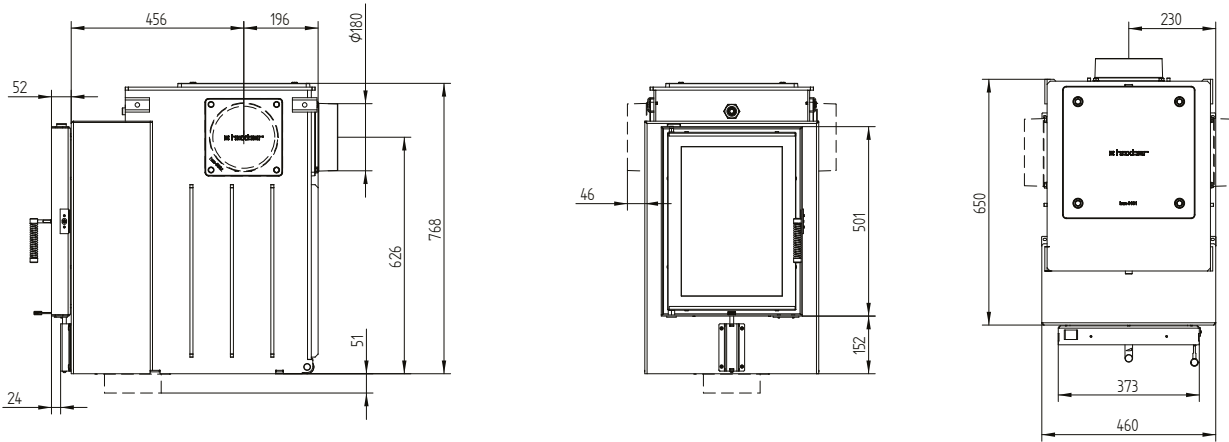

HE 37/50G cupola Ø180 with opening for cleaning

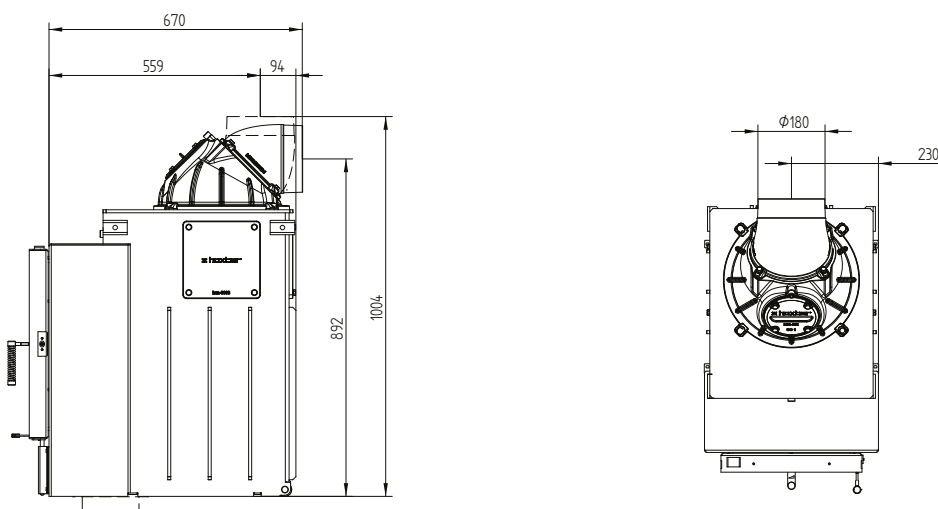

HE 37/50G

Technical data
Version 09/2023

HE 37/50G support frame / vertical air inlet adaptor

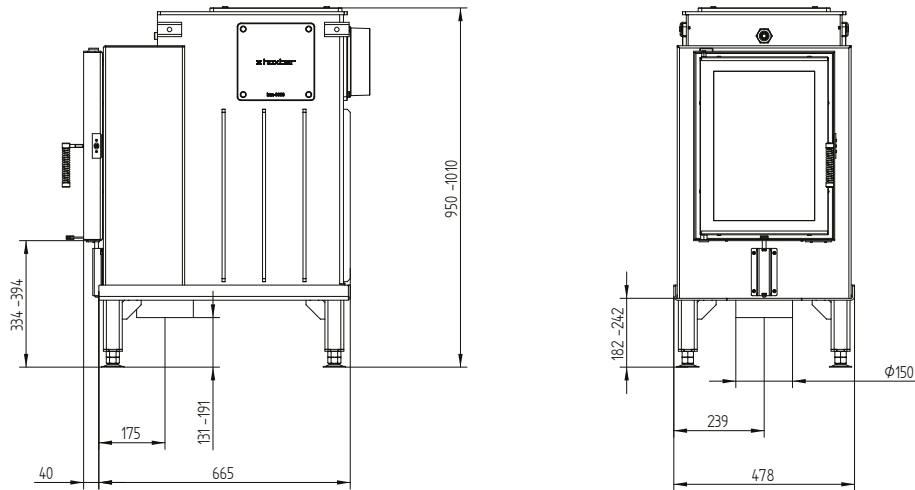

HE 37/50G support frame / horizontal air inlet adaptor / feet

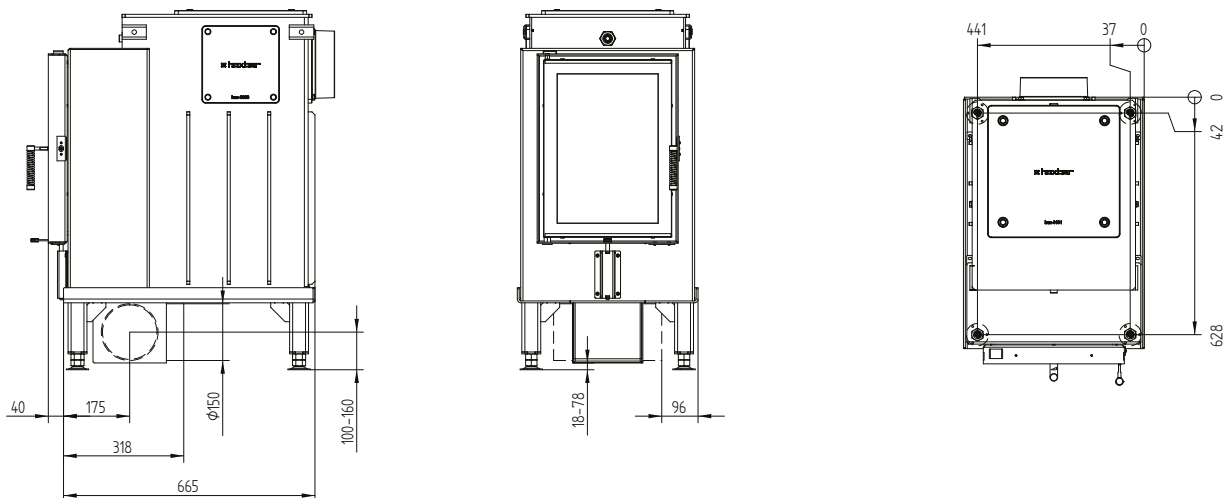

HE 37/50G

Technical data
Version 09/2023

Cover frame 37/50G 4sides 80 mm 2 x 45°

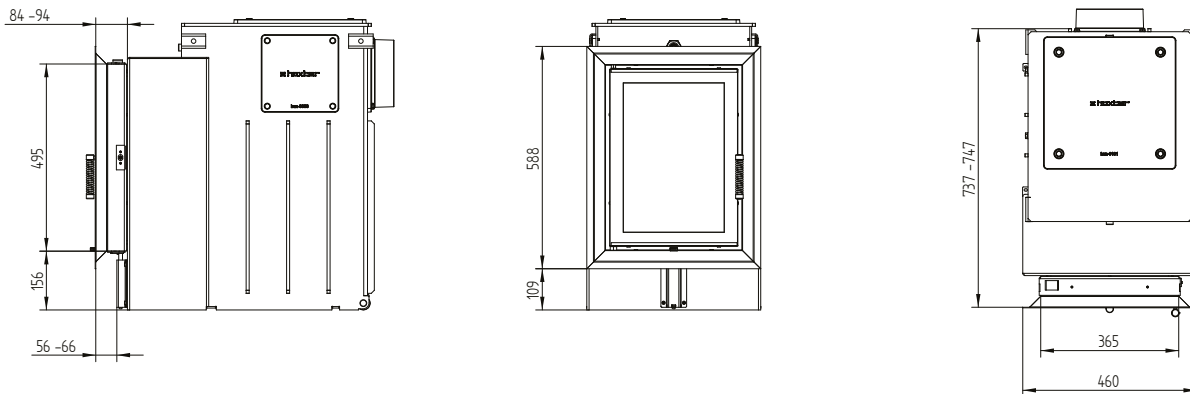

Cover frame 37/50G 4sides 50 mm 1 x 90°

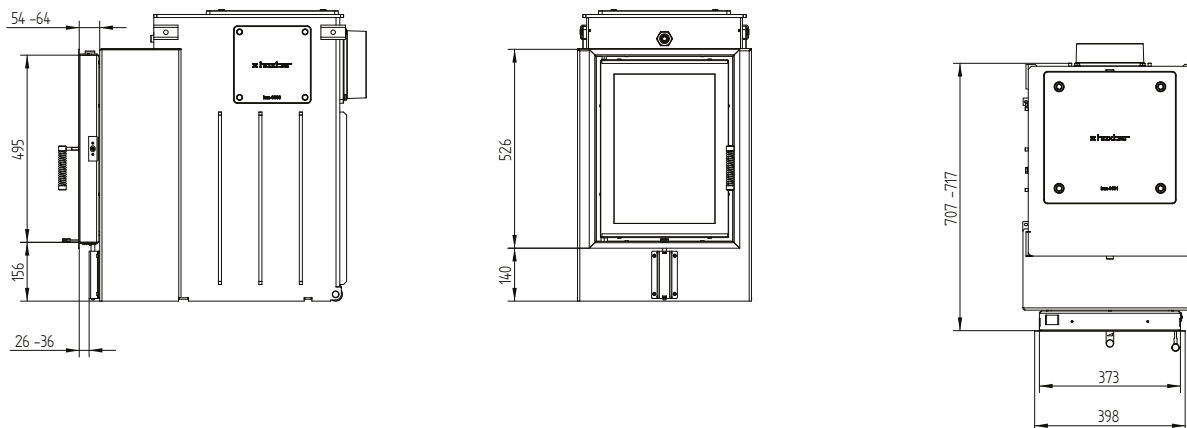

Front panel 37/50G - 830 x 480 mm

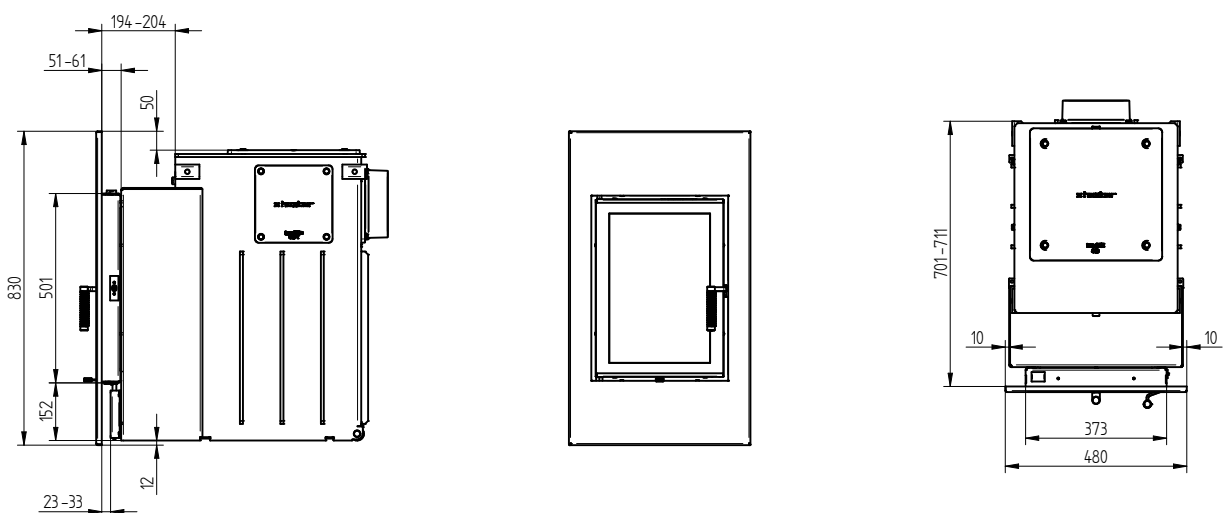

M 1:20